

# Reactor Internals

## AlphaPLUS REACTOR INTERNALS - OVERVIEW

HAT supplies a complete range of internals designed for gas/liquid/solid mixed phase reactors in petrochemical applications such as:

- Adsorbers and Regenerators
- HDS & Hydrotreaters
- Polymerisation Units
- Ammonia Reactors
- Reformers
- etc

These vessels tend to utilise licensed or proprietary know-how and hence there is a requirement to manufacture specialist internals built to the technology provider's drawings. HAT brings particular expertise to these situations because of the experience and know-how we maintain in the detailed engineering of such components.

Some examples of these internals supplied by HAT are shown below. Materials of construction have included carbon and stainless steels, inconel and titanium.

### Distributors & Baskets:



#### **SID Slotted Inlet Distributors**

Available plain or with wire mesh or wedge wire covering.



#### **OB Wedge Wire Outlet Baskets**

A reinforced design to withstand the compression forces.



#### **RFB Radial Flow Baskets**

Custom engineered to retain the catalyst whilst providing free flow.

### Trays:



#### **RTD Gas/Liq Distributor Trays**

Widely used for multi-phase flow applications.



#### **RTS Reactor Sieve Trays**

A standard design where liquid hold-up is required.

# Reactor Internals

## Grids & Screens:



### RTX Special Trays

Custom engineered and manufactured to client's design.

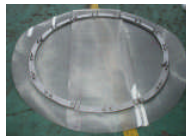

### FS Floating Screens - Mesh

An economic and effective barrier between media layers.



### FXS Fixed Screens - Wedge Wire or Mesh

A widely used bottom screen, resting on a support grid.



### SG Support Grids

A range of designs to accommodate most applications.

Mechanical design of these internals and their support beams can be undertaken or checked by HAT using the latest finite element design methods as per the example illustrated below:

### Finite Element on Support Beam – Deflection

Beam Deflection (vertical load only)  
Max Displacement 2.324mm

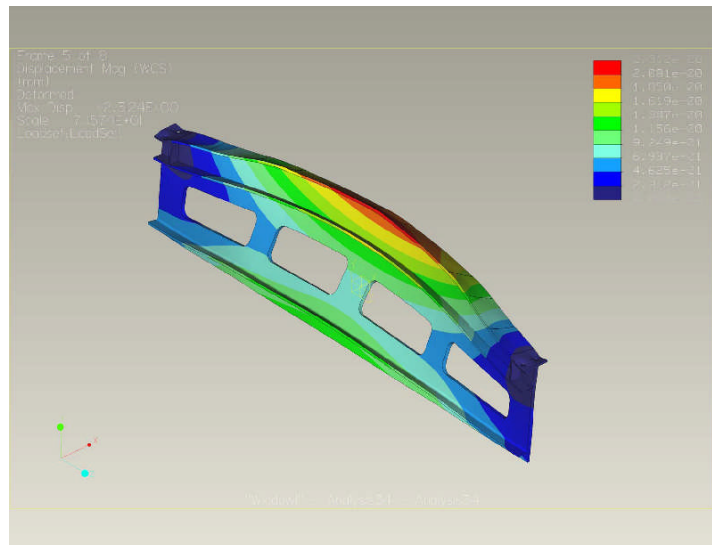



## Supports & Screens

### AlphaPLUS™ REACTOR INTERNALS

HAT supplies a complete range of internals designed for solid bed reactors such as:

- Molecular Sieve Treaters
- Activated Carbon Beds
- Desiccant Towers
- Catalyst Beds

Typical requirements will include **AlphaPLUS™** inlet and outlet distributor baskets, wedge wire ('Johnson') support screens, floating wire mesh screens, support grids and consumables such as ceramic or alumina support balls, activated carbon, alumina and molecular sieves (**AlphaCHEM™** consumables are normally supplied as part of an overall package).

### BS Inlet/Outlet Baskets

These are devices to ensure correct process fluid distribution as well as to prevent the exit of any large solid particles from the vessel. Many reactors operate with regeneration cycles where flow reversal occurs, so the baskets are designed for two way operation.

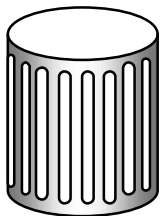

Construction typically comprises an inner 'can' with slotted perforations to provide the correct open area, velocity and distribution profile, covered with a coarse mesh or wedge wire screen and sometimes a fine mesh filter layer, depending on the application.

### WWS Wedge Wire Screens

This style of screen has taken a large slice of the filter / strainer market from traditional gauzes because of the obvious backflow self-cleaning characteristic due to the tapered shape of the bars.

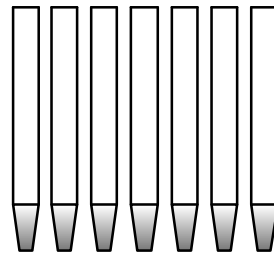

When used as bed supports, the bar size is calculated to support the mechanical load imposed by the bed, and the spacing is selected to suit the

flow and bed particle size characteristics. The wedge wire screens are manufactured in sections to pass through vessel manways, and are usually themselves supported on a lattice grid giving further mechanical strength.

### FS & FXS Mesh Screens

Standard mesh screens or gauzes are the workhorses of the industry.

They are available in a very wide range of mesh sizes, wire diameters, materials and weaves and are generally a very economic solution.

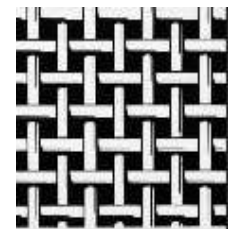

Uses in reactors include **FS** Floating Screens between layers of bed chemicals, **FXS** Fixed Screens to prevent exit of particles, and seals around the perimeter of support plates or for instrumentation tappings.



# Supports & Screens

**Fig.1 Typical Supports and Screens in a Reactor**

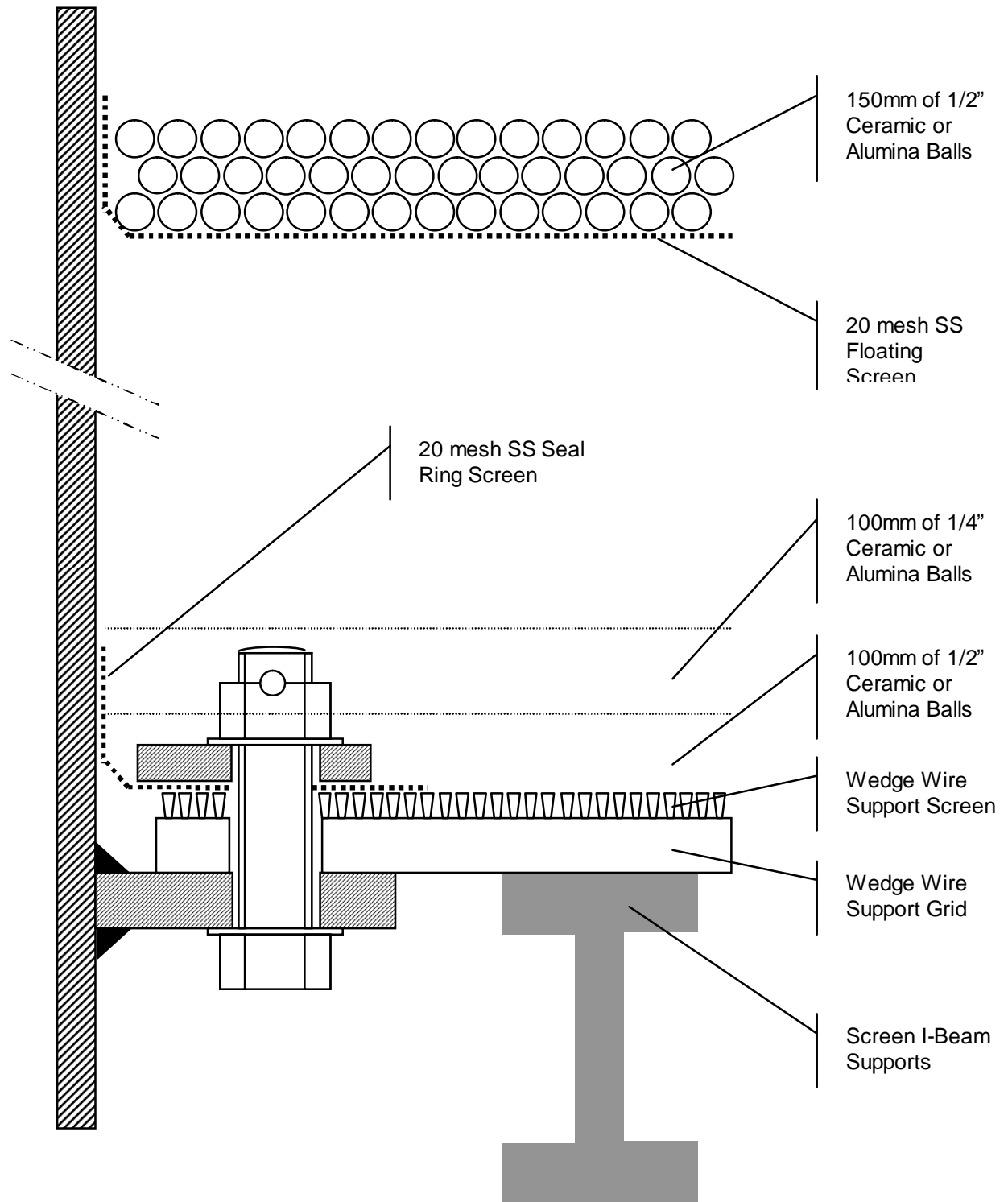



# Supports & Screens

**Table 1. Common Mesh Screen Sizes**

Mesh Size (Openings per Inch)	Wire SWG	Wire Dia mm	Aperture mm	% Open Area	Weight kg/m <sup>2</sup>
4	18	1.25	5.10	64	3.11
6	18	1.25	2.98	50	4.66
8	20	0.90	2.28	51	3.21
10	22	0.71	1.83	51	2.50
12	24	0.56	1.56	54	1.87
14	26	0.45	1.36	56	1.41
16	26	0.45	1.14	51	1.61
18	27	0.40	1.01	51	1.43
20	28	0.36	0.92	52	1.25
24	28	0.36	0.70	44	1.50
28	28	0.36	0.55	37	1.75
30	30	0.31	0.53	39	1.48
36	33	0.25	0.46	41	1.12
40	34	0.22	0.41	42	1.00
50	35	0.20	0.31	37	0.99
60	36	0.18	0.26	39	0.85
70	38	0.16	0.20	32	0.89
80	39	0.14	0.18	31	0.78
100	42	0.10	0.15	37	0.50

*Mesh sizes are also available in other wire diameters and % open areas. Weight is for SS316.*

**Table 2. Wedge Wire Data**

Nominal Mesh Size	Wire Depth mm	Wire Width mm (Max)	Aperture mm	% Open Area	Weight kg/m <sup>2</sup>
4	8	3.00	5.00	62	26.7
6	8	3.00	3.00	50	35.2
8	8	3.00	2.50	45	38.7
10	6	2.00	2.00	50	26.4
12	6	2.00	1.50	43	30.1
14	6	2.00	1.30	39	32.2
16	5	1.75	1.15	39	26.8
18	5	1.75	1.00	36	28.2
20	5	1.75	0.90	34	29.0

*The above data is typical only – screens are custom built to the application.*